

EIPH2 EIPH3 EIPH6

INTERNAL GEAR PUMPS

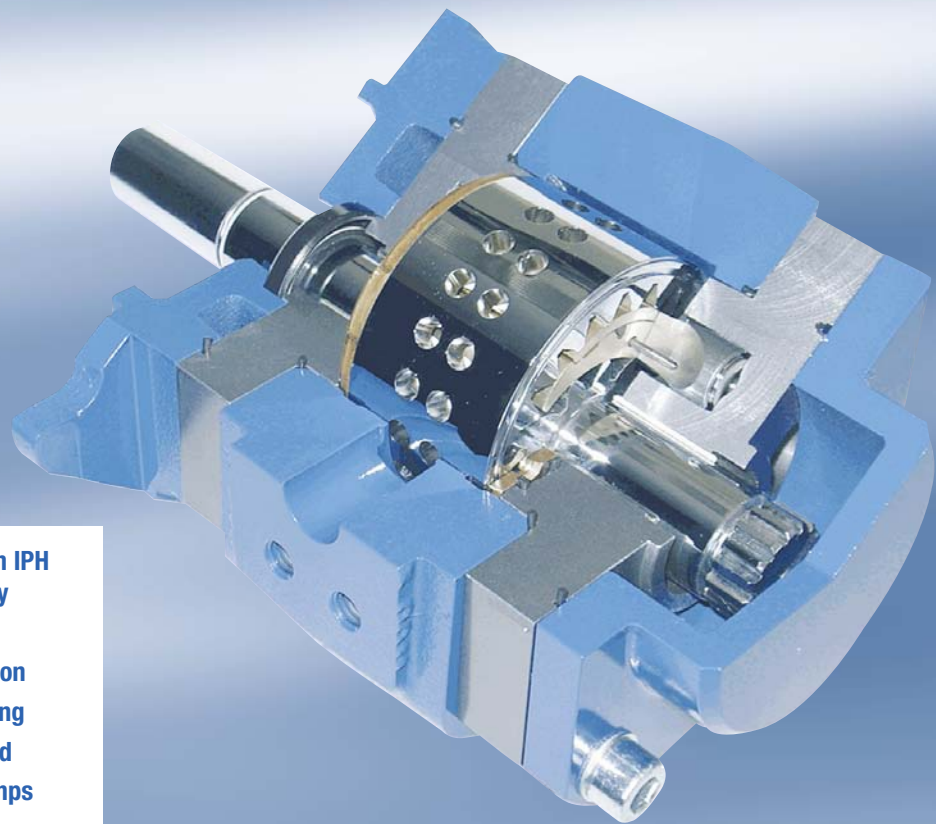

- new Generation IPH
new technology
- up to 400 bar
- industrial version
- cast iron housing
- noise-optimized
- multi-flow-pumps
with common
suction port



Photo: Trumpf

Internal gear pump Type EIPH2 high pressure pump with constant displacement volume



EIPH2

Characteristics

- Internal gear pump with axial and radial gap compensation
- Radial compensation with segments
- Suction and pressure port radial
- Field of application: Industrial hydraulic
- Low noise
- Long time life
- Low pulsation (pressure pulsation ~ 2%)
- Multi flow combinations

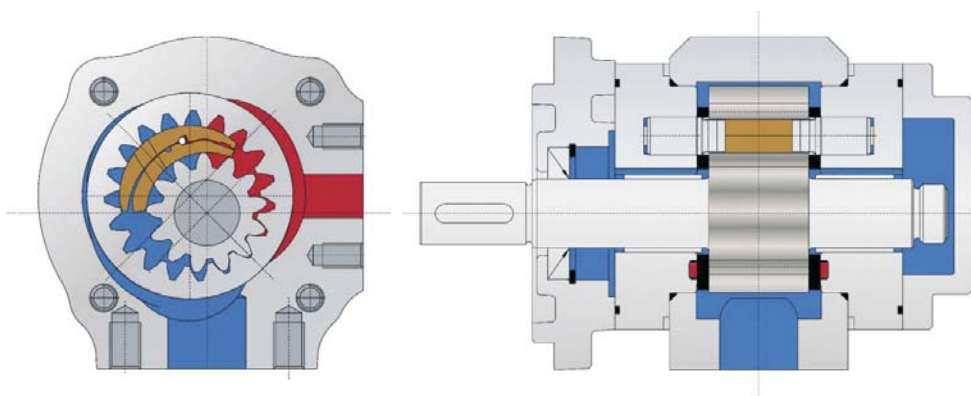

Technical Data:

Rated Size NG	004	005	006	008	011	013	016	019	022	025
Spec. volume V _{th} [cm ³ /rev.]***	4.2	5.4	6.4	7.9	10.9	13.3	15.8	19.3	22.2	25.2
Continuous operating pressure [bar]**	330			300			250		250	
Peak operating pressure [bar] max.10 sec.15% dutycycle**	350			300			280		280	
Cut-in pressure peak [bar]**	400			325			300		300	
Max. speed [rpm]	4,200			4,000			3,600			
Nominal speed [rpm]	400 – 4,000			400 – 3,600			400 – 3,000			
Operating viscosity [mm ² /s]	10 – 300									
Starting viscosity [mm ² /s]	2,000									
Operating medium	HL – HLP DIN 51 524 part 1/2									
Max. medium temperature [°C]	80									
Min. medium temperature [°C]	-20									
Max. ambient temperature [°C]	80									
Min. ambient temperature [°C]	-20									
Max. admission pressure (intake side) [bar]	2 bar absolute									
Min. admission pressure (intake side) [bar]	0.8 bar absolute (Start 0.6)									
Weight appr. [kg]	4.9	4.9	5.0	5.2	5.4	5.5	5.7	7.4	7.8	8
Degree of filtration	Class 20/18/15 due to ISO 4406									

Efficiency η_{vol}	88	91	92	93	93	94	95	95	95	95
Efficiency η_{hm}	85	90	90	91	92	92	93	93	93	93
Pump noise* (measured in sound chamber) dB[A]	53	54	55	57	58	59	60	61	62	63
n = 1.450 $\Delta p = 250$ bar T = 50 °C Medium: HLP 46										
*Measured in anechoic room of Eckerle Hydraulic Division; Axial microphone distance 1.0 m										

** For acceptable pressure at 400-1.800 rpm. Further rpm on request.

*** Due to manufacturing tolerances the displacement volume could vary.

Internal gear pump Type EIPH3 high pressure pump with constant displacement volume



EIPH3

Characteristics

The new series EIPH were developed particularly for the high requirements of industrial hydraulics. Their favourable noise characteristic, extremely low delivery and pressure pulsation, outstanding efficiency within broad revolution and viscosity ranges, have firmly established gap-compensated high pressure internal gear pumps among high pressure pumps. Simple combinability to multiple pumps with separate or common inlet is given.

The EIPH is a consistent advancement that already for over 40 years in the industry used gap-compensated internal gear pump technology, System Eckerle.

Technical Data:

Rated Size NG	014	016	020	025	032	040	050	064
Spec. volume V_{th} [cm ³ /rev.]***	14.6	16.0	20.0	24.8	32.1	40.1	50.3	64.6
Continuous operating pressure [bar]**	330			300			280	
Peak operating pressure [bar] max.10 sec.15% dutycycle**	350			300			300	
Cut-in pressure peak [bar]**	400			325			325	
Max. speed [rpm]	4,000		3,000			2,500		1,800
Nominal speed [rpm]	400 – 3,600		400 – 2,800			400 – 2,200		400–1,800
Operating viscosity [mm ² /s]	10 – 300							
Starting viscosity [mm ² /s]	2,000							
Operating medium	HL – HLP DIN 51 524 part 1/2							
Max. medium temperature [°C]	80							
Min. medium temperature [°C]	-20							
Max. ambient temperature [°C]	80							
Min. ambient temperature [°C]	-20							
Max. admission pressure (intake side) [bar]	2 bar absolute							
Min. admission pressure (intake side) [bar]	0.8 bar absolute (Start 0.6)							
Weight appr. [kg]	9.4	10.1	10.5	11.2	12.0	15	17	18
Degree of filtration	Class 20/18/15 due to ISO 4406							
Efficiency η_{vol}	91	92	93	93	94	95	95	95
Efficiency η_{hm}	90	90	91	92	92	93	93	93
Pump noise* (measured in sound chamber) dB[A]	60	61	62	63	64	65	66	66
$n = 1.450$ $\Delta p = 250 \text{ bar}$ $T = 50 \text{ °C}$ Medium: HLP 46								
*Measured in anechoic room of Eckerle Hydraulic Division; Axial microphone distance 1.0 m								

** For acceptable pressure at 400-1.800 rpm. Further rpm on request.

*** Due to manufacturing tolerances the displacement volume could vary.

Internal gear pump
Type EIPH6 high pressure pump
with constant displacement volume



EIPH6

Technical Data:

Rated Size NG	040	050	064	080	100	125	160	200	250
Spec. volume V _{th} [cm ³ /rev.]***	40.8	50.6	65.3	80.0	101.2	125.7	160.1	200.9	249.9
Continuous operating pressure [bar]**	330		315	300		250		160	140
Peak operating pressure [bar] max. 10sec 15% duty cycle**	340		330	330		280		170	150
Cut-in pressure peak [bar]**	350		340	340		300		180	160
Max. speed [rpm]	2.400			2.200			2.000		
Nominal speed [rpm]	400 – 2,200			400 – 2,000			400 – 1,800		
Operating viscosity [mm ² /s]	10 – 300								
Starting viscosity [mm ² /s]	2.000								
Operating medium	HL – HLP DIN 51 524								
Max. medium temperature [°C]	80								
Min. medium temperature [°C]	-20								
Max. ambient temperature [°C]	80								
Min. ambient temperature [°C]	-20								
Max. admission pressure (intake side) [bar]	2 bar absolute								
Min. admission pressure (intake side) [bar]	0,8 bar absolute								
Weight appr. [kg]:	31	32	34	36	39	42	46	51	58
Degree of filtration	Class 20/18/15 due to ISO 4406								
Efficiency η _{vol}	93	93	94	94	95	95	96	96	96
Efficiency η _{hm}	89		90			91			
Pump noise* (measured in sound chamber) dB[A]	72	73	74	75	76	76	77	77	78
	n = 1.450		Δ p = 250 bar			T = 50 °C		Medium: HLP 46	
	*Measured in anechoic room of Eckerle Hydraulic Division; Axial microphone distance 1.0 m								

** For acceptable pressure at 400-1,800 rpm. Further rpm on request.

*** Due to manufacturing tolerances the displacement volume could vary.



Pump with SAE-A-2-hole flange and cylindrical shaft

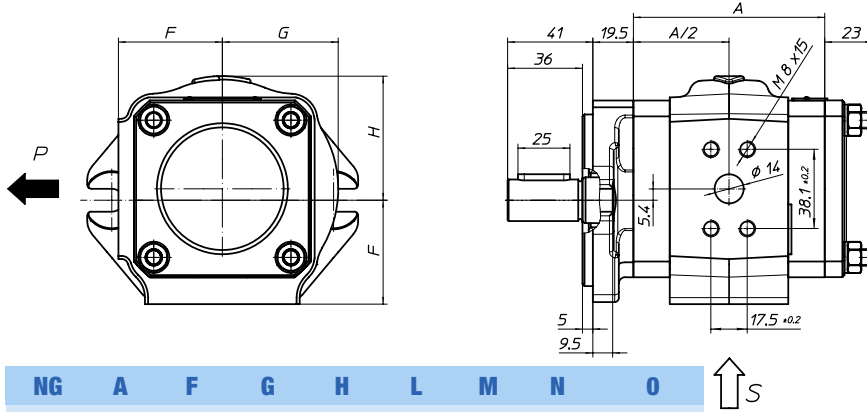

Order example: EIPH2- ___ RK03-1X

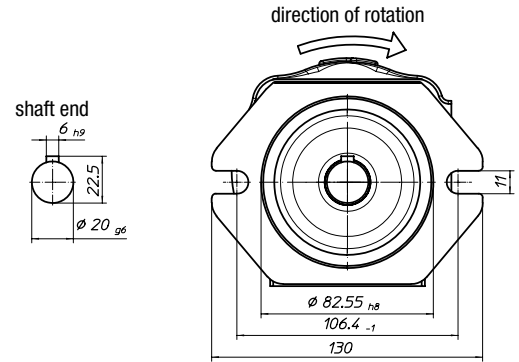

NG	A	F	G	H	L	M	N	O
004	71	50	54	57	38,1	17,5	14	M8x15
005	71	50	54	57	38,1	17,5	14	M8x15
006	73	50	54	57	47,5	22	19	M10x16
008	76	50	54	57	47,5	22	19	M10x16
011	82	50	54	57	52,4	26,2	25	M10x17
013	87	50	54	57	52,4	26,2	25	M10x17
016	92	50	54	57	52,4	26,2	25	M10x17
019	99	55	59	62	52,4	26,2	25	M10x17
022	105	55	59	62	52,4	26,2	25	M10x17
025	111	55	59	62	52,4	26,2	25	M10x17

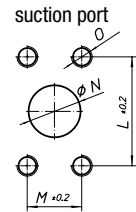

Double Pump with SAE-A-2-hole flange and cylindrical shaft

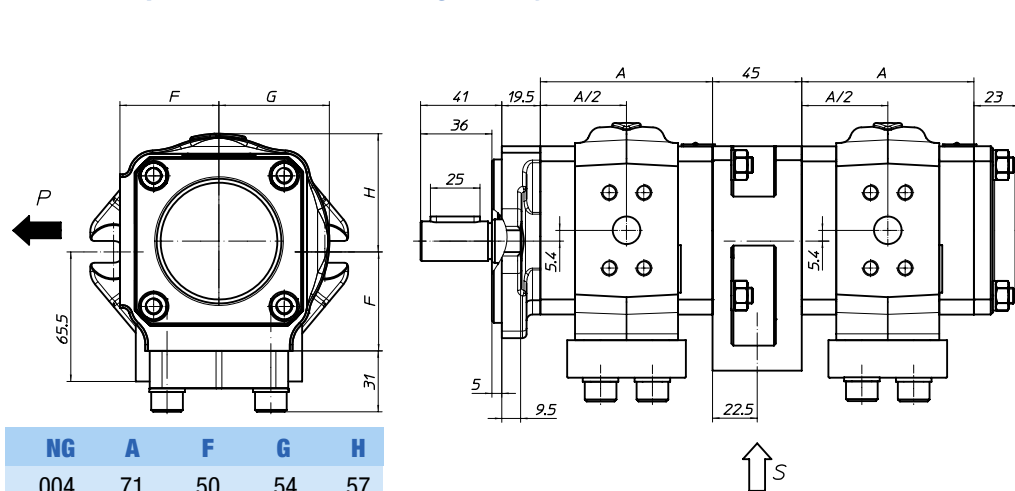

Order example: EIPH2- ___ RK00-1X+
EIPH2- ___ RP30-1X

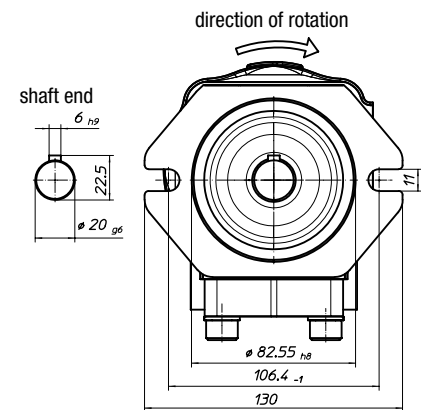

NG	A	F	G	H
004	71	50	54	57
005	71	50	54	57
006	73	50	54	57
008	76	50	54	57
011	82	50	54	57
013	87	50	54	57
016	92	50	54	57
019	99	55	59	62
022	105	55	59	62
025	111	55	59	62

Common suction port
pump size NG 004-016 pump size NG 019-025

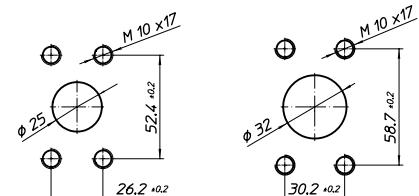

Pressure connections see single pumps



Pump with SAE-B-2-hole flange and cylindrical shaft

Order example: EIPH3- __ _RK23-1X

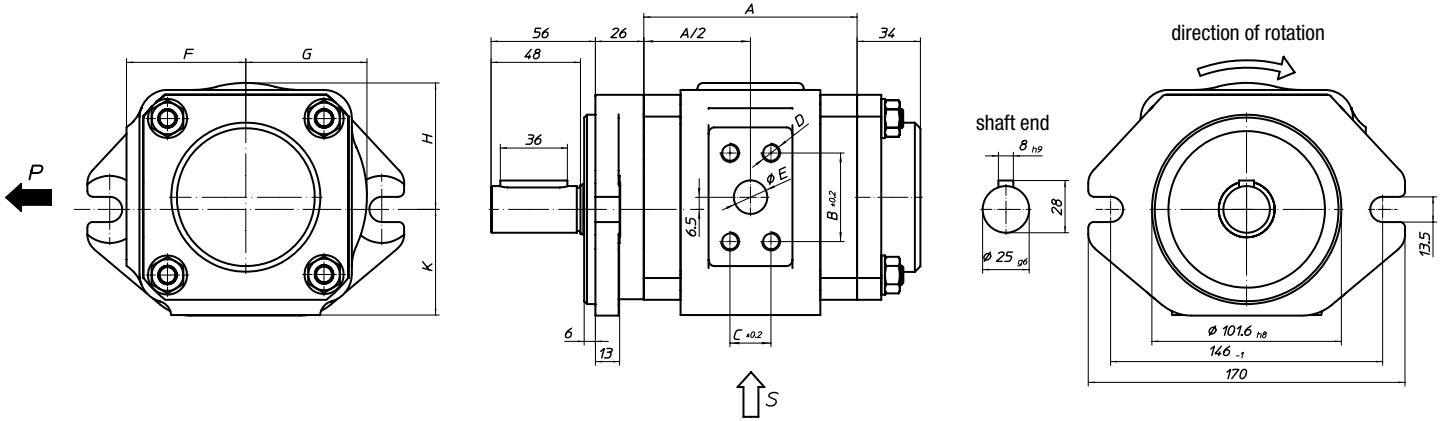

NG	A	B	C	D	E	F	G	H	K	L	M	N	O
014	90,4	38,1	17,5	M8x15	14	64	65	67	57	52,4	26,2	25	M10x17
016	92,4	38,1	17,5	M8x15	14	64	65	67	57	52,4	26,2	25	M10x17
020	97,9	47,5	22	M10x17	18	64	65	67	57	58,7	30,2	32	M10x17
025	104,4	47,5	22	M10x17	18	64	65	67	57	58,7	30,2	32	M10x17
032	114,4	47,5	22	M10x17	18	64	65	67	57	58,7	30,2	32	M10x17
040	125,4	52,4	26,2	M10x17	20	70	73	79	63	58,7	30,2	32	M10x20
050	139,4	52,4	26,2	M10x17	20	70	73	79	63	58,7	30,2	32	M10x20

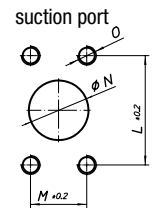

Double Pump with SAE-B-2-hole flange and cylindrical shaft

Order example: EIPH3- __ _RK20-1X+
EIPH3- __ _RP30-1X

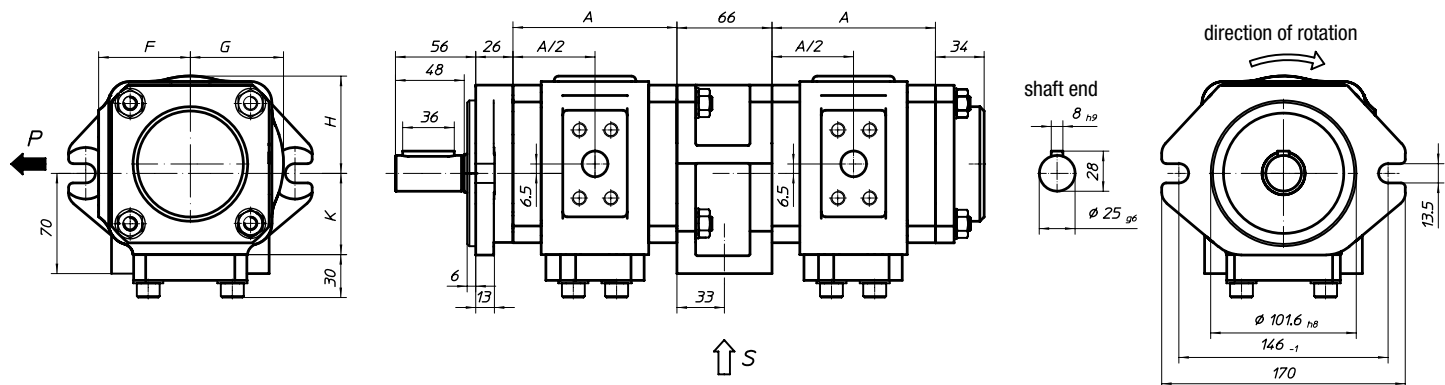

NG	A	F	G	H	K
014	90,4	64	65	67	57
016	92,4	64	65	67	57
020	97,9	64	65	67	57
025	104,4	64	65	67	57
032	114,4	64	65	67	57
040	125,4	70	73	79	63
050	139,4	70	73	79	63

Pressure connections see single pumps

Common suction port
pump size NG 014-032 pump size NG 040-050

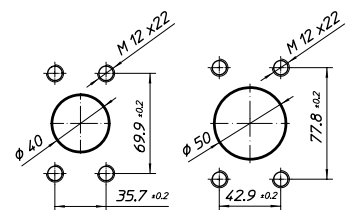

Dimensions



EIPH3/2

Double Pump with SAE-B-2-hole flange and cylindrical shaft

Order example: EIPH3-___RK20-1X+
EIPH2-___RP30-1X

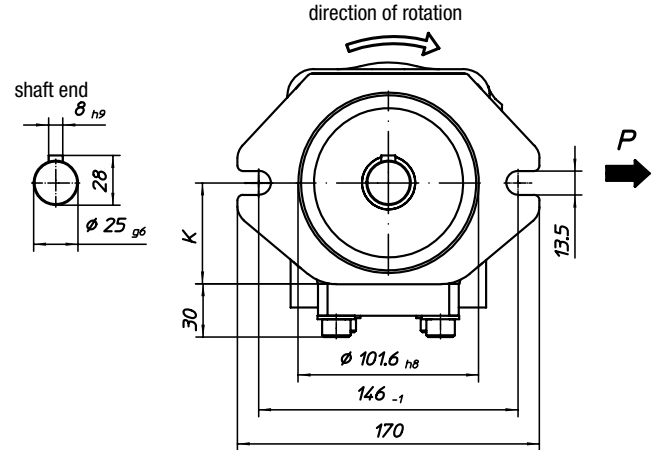
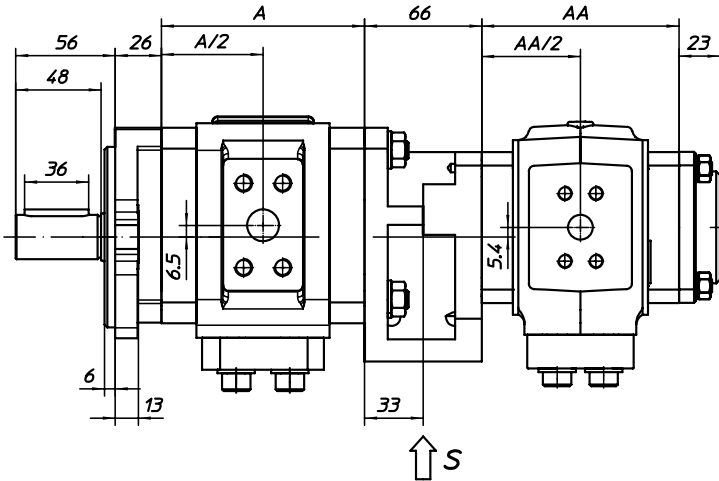

EIPH3					
NG	A	F	G	H	K
014	90,4	64	65	67	57
016	92,4	64	65	67	57
020	97,9	64	65	67	57
025	104,4	64	65	67	57
032	114,4	64	65	67	57
040	125,4	70	73	79	63
050	139,4	70	73	79	63

EIPH2				
NG	AA	FF	GG	HH
004	71	50	54	57
005	71	50	54	57
006	73	50	54	57
008	76	50	54	57
011	82	50	54	57
013	87	50	54	57
016	92	50	54	57
019	99	55	59	62
022	105	55	59	62
025	111	55	59	62

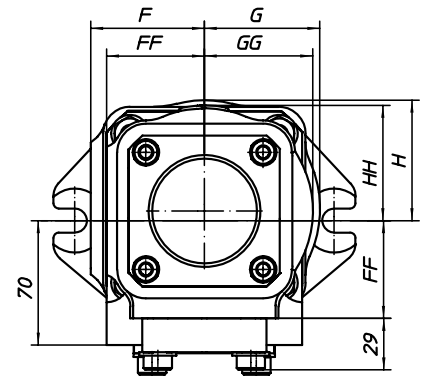

Pressure connections see single pumps

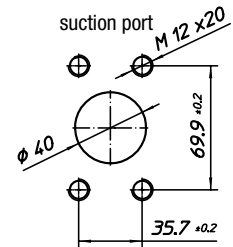

The single pumps of a multiple pump assembly are internally connected, even if you connect to the pump inlet. It is therefore no operating with different fluids possible.



Pump with SAE-D-2-hole flange and cylindrical shaft

Order example: EIPH6- ___ RK23-1X

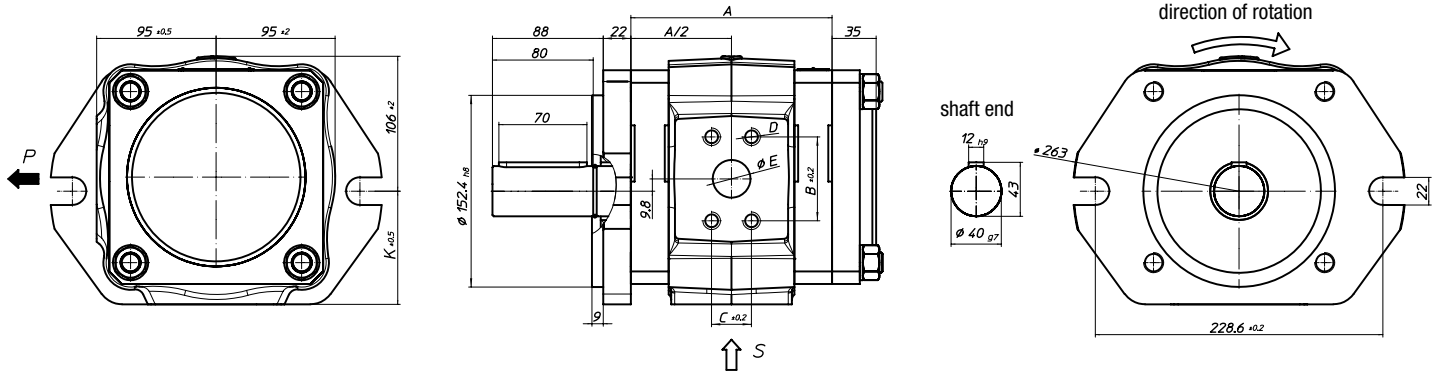

NG	A	B	C	D	E	K	L	M	N	O
040	123	57,2*	27,8*	M12x22	20	90	69,9	35,7	35	M12x25
050	129	57,2*	27,8*	M12x22	20	90	69,9	35,7	40	M12x25
064	138	57,2*	27,8*	M12x22	20	90	69,9	35,7	40	M12x25
080	147	66,7*	31,8*	M14x25	30	90	77,8	42,9	50	M12x25
100	160	66,7*	31,8*	M14x25	30	90	77,8	42,9	50	M12x25
125	175	66,7*	31,8*	M14x25	30	90	77,8	42,9	50	M12x25
160	196	66,7*	31,8*	M14x25	30	90	88,9	50,8	65	M12x25
200	221	79,4*	36,5*	M16x25	38	92	106,4	61,9	76	M16x25
250	251	79,4*	36,5*	M16x25	38	92	106,4	61,9	76	M16x25

* Pressure port: SAE 518C, high pressure series (code 62)

Double Pump with SAE-D-2-hole flange and cylindrical shaft

Order example: EIPH6- ___ RK20-1X+
EIPH6- ___ RP30-1X

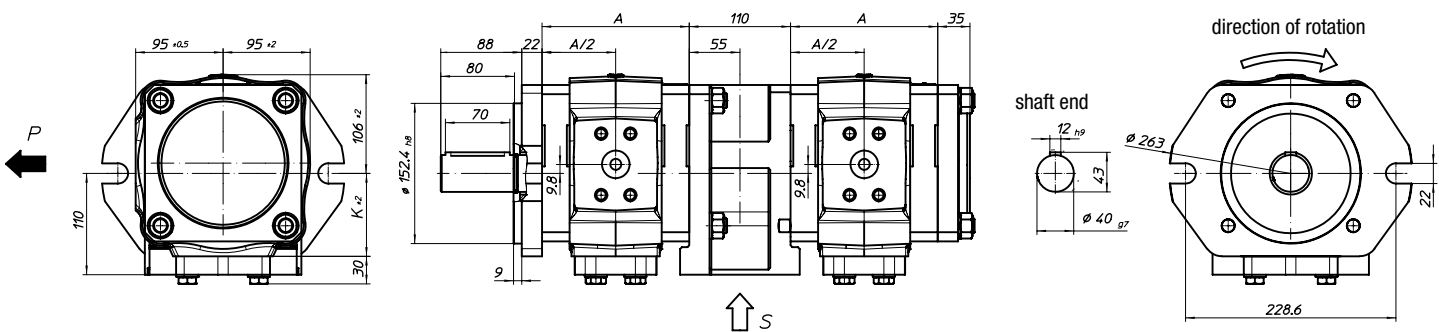

NG	A
040	123
050	129
064	138
080	147
100	160
125	175
160	196
200	221
250	251

From NG 160 is no common suction available

Pressure connections see single pumps

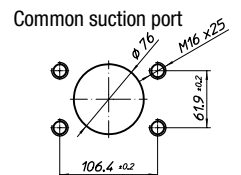



Double Pump with SAE-D-2-hole flange and cylindrical shaft

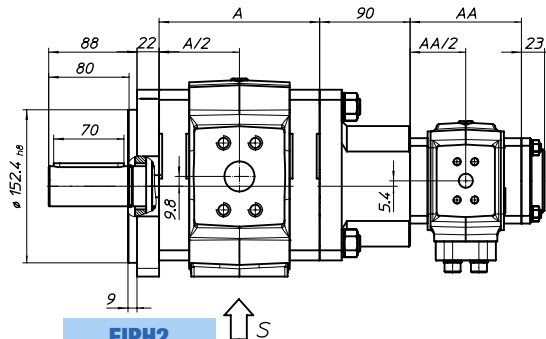
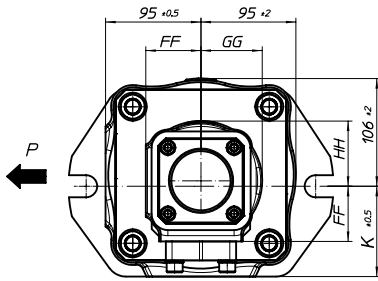

Order example: EIPH6- ___ RK23-1X+

EIPH2- ___ RP30-1X

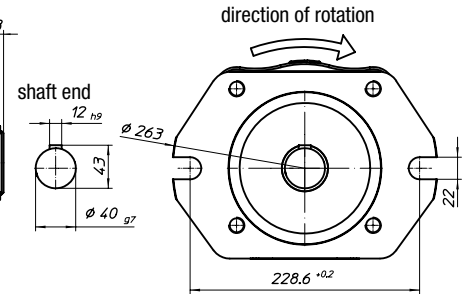

EIPH6						
NG	A	K	L	M	N	O
040	123	90	69,9	35,7	35	M12x25
050	129	90	69,9	35,7	40	M12x25
064	138	90	69,9	35,7	40	M12x25
080	147	90	77,8	42,9	50	M12x25
100	160	90	77,8	42,9	50	M12x25
125	175	90	77,8	42,9	50	M12x25
160	196	90	88,9	50,8	65	M12x25
200	221	92	106,4	61,9	76	M16x25
250	251	92	106,4	61,9	76	M16x25

EIPH2				
NG	AA	FF	GG	HH
004	71	50	54	57
005	71	50	54	57
006	73	50	54	57
008	76	50	54	57
011	82	50	54	57
013	87	50	54	57
016	92	50	54	57
019	99	55	59	62
022	105	55	59	62
025	111	55	59	62

Pressure connections see single pumps

Common suction port

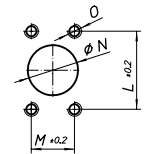

Double Pump with SAE-D-2-hole flange and cylindrical shaft

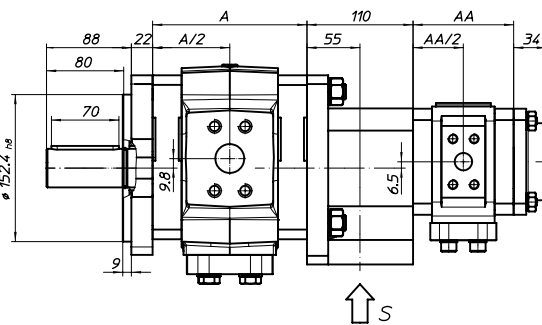
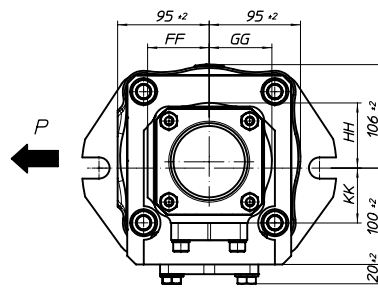

Order example: EIPH6- ___ RK20-1X+

EIPH3- ___ RP30-1X

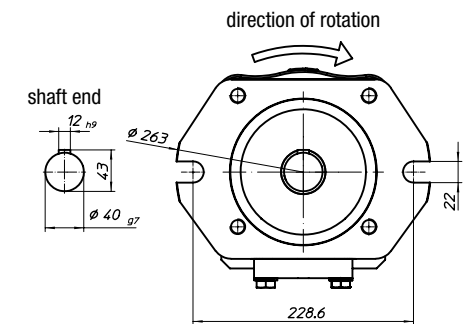

EIPH6		EIPH3					
NG	A	NG	AA	FF	GG	HH	KK
040	123	014	90,4	64	65	67	57
050	129	016	92,4	64	65	67	57
064	138	020	97,9	64	65	67	57
080	147	025	104,4	64	65	67	57
100	160	032	114,4	64	65	67	57
125	175	040	125,4	70	73	79	63
160	196	050	139,4	70	73	79	63
200	221						
250	251						

Pressure connections see single pumps

Common suction port

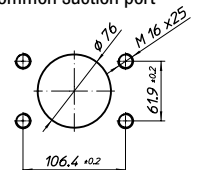



SAE flange metric tapped



Version a

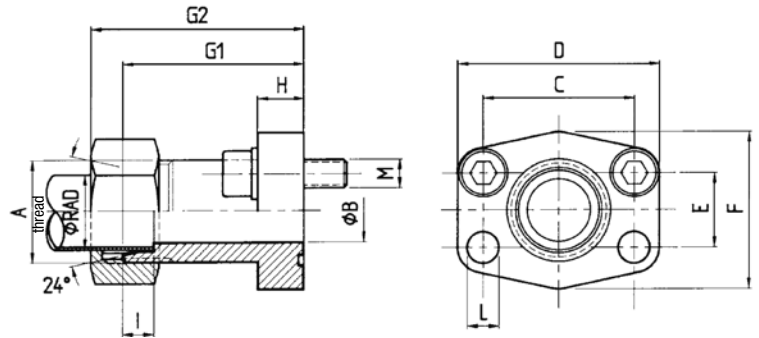

SAE pipe threaded flange



Version b

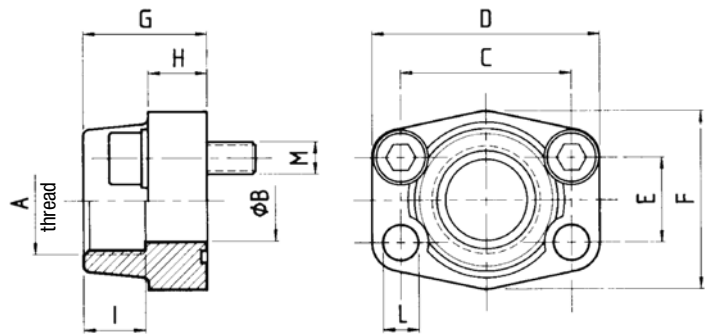

Nr.	Article number	Type	P _{max}	AD	A	B	C	D	E	F	G1	G2	H	I	L
1a	07 07 04 0030	AD15-SAE12M22x1,5	315	15	M22x1.5	12	38.1	54	17.48	46	52	60	13	7	9
1b	07 07 04 0026	EFG1/2-SAE12	350		G1/2"	13	38.1	54	17.48	46	36		19	19	9
2a	07 07 04 0031	AD22-SAE34M30x2	160	22	M30x2	19	47.63	65	22.23	50	60	69	14	7.5	11.5
2b	07 07 04 0027	EFG3/4-SAE34	350		G3/4"	19	47.63	65	22.23	50	36		18	19	11
3a	07 07 04 0032	AD28-SAE100M36x2	160	28	M36x2	24	52.37	70	26.19	55	63	72	16	7.5	11.5
3b	07 07 04 0028	EFG1-SAE100	315		G1"	25	52.37	70	26.19	55	38		18	22	11
4a	07 07 04 0033	AD35-SAE114M45x2	160	35	M45x2	29	58.72	79	30.18	68	65	76	14	10.5	11.5
4b	07 07 04 0029	EFG1 1/4-SAE114	250		G1 1/4"	32	58.72	79	30.18	68	41		21	22	11.5
5a	07 07 04 0037	AD42-SAE112M52x2	160	42	M52x2	36	69.85	94	35.71	78	70	82	16	11	13.5
5b	07 07 04 0034	EFG1 1/2-SAE112	200		G1 1/2"	38	69.85	94	35.71	78	45		25	24	13.5
6b	07 07 04 0036	EFG2-SAE200	200		G2"	51	77.77	102	42.88	90	45		25	30	13.5
7b	07 07 04 0041	EFG2 1/2-SAE212	160		G2 1/2"	63	88,9	114	50.8	105	50		25	30	13.5
8a	07 07 04 0042	AD30-SAE100M42x2HD	400	30	M42x2	25	57.2	81	27.8	70	82	95	24	13.5	13
9a	07 07 04 0043	AD38-SAE114M52x2HD	400	38	M52x2	32	79.38	113	36.5	95	96	111	30	16	17.5



SAE Pressure- and Suction flange SAE J 518C, ISO 6162

Type	Inlet	Nr.	Version		Outlet	Nr.	Version	
			a	b			a	b
EIPH2-004-005	1/2"	1	•	•	1/2"	1	•	•
EIPH2-006-008	3/4"	2	•	•	1/2"	1	•	•
EIPH2-011-025	1"	3	•	•	1/2"	1	•	•
EIPH3-014-016	1"	3	•	•	1/2"	1	•	•
EIPH3-020-032	1 1/4"	4	•	•	3/4"	2	•	•
EIPH3-040-064	1 1/4"	4	•	•	1"	3	•	•
EIPH6-040-064	1 1/2"	5	•	•	1" *	8	•	
EIPH6-080-125	2"	6		•	1 1/4" *	9	•	
EIPH6-160	2 1/2"	7		•	1 1/4" *	9	•	

*High pressure range

Suction flange for Intermediate housing

Type	Inlet	Nr.	Version	
			a	b
EIPH2/2 - NG004-NG016	1"	3	•	•
EIPH2/2 ab NG019	1 1/4"	4	•	•
EIPH3/3 bis NG032	1 1/2"	5	•	•
EIPH3/3 ab NG040	2"	6		•
EIPH6/6			○	○
EIPH6/3			○	○
EIPH6/2			○	○

• = available ○ = on request



EIP H2-016RK03-10 S123

Special version number (not applicable with standard pumps or when the type key is unambiguous)

Revision code 1st number: Change of mounting dimensions
2nd number: Change of pump with same mounting dimensions

Intake and delivery connection 3: SAE-flange connections
– other flanges on request –
0: suction port closed; common inlet

Fastening flange 0: SAE/A 2-hole flange, centre-Ø 82.55
2: SAE/B 2-hole flange, centre-Ø 101.6
2: SAE/D 2-hole flange, centre-Ø 152.4 at EIPH 6
3: Direkt fixture
5: VDMA on demand
– other flanges on request –

Shaft end K: Cylindrical with cone
P: Cone tooth system on both sides
cone is standard;
(cone = add-on facility for additional pumps to create multiple-flow pumps)

Sense of rotation R: Clockwise
L: Anticlockwise

Rated size, three digits

Overall size 2 or 3 or 6

Type H: High pressure pump

Eckerle internal gear pump

Order example

EIPH2 - 016 RK03 - 1X

High pressure pump
overall size 2 with 15,8 cm³/U
clockwise rotation
cylindrical shaft with cone
SAE/B-2-hole flange connection
SAE flange connection
revision code 1X



ECKERLE
HYDRAULIC DIVISION

Eckerle Industrie-Elektronik GmbH · P.O. box 1368
Otto-Eckerle-Str. 6/12A · D-76316 Malsch
Phone: +49 (0) 72 46/92 04-0 · Fax: +49 (0) 72 46/92 04-946
sales.ehd@eckerle.com · www.eckerle.com