



Features

■ Non lubrication

Special housing and bushing enables self lubrication of piston rod.

■ High quality long service life

Hard anodised stainless steel cylinder tubes offer a high resistance to corrosion and low internal friction.

■ Cylinder mountings

Available with a comprehensive range of accessories for rigid or flexible mounting.

■ ISO-6432 standard

Enables world-wide inter-changeability.

■ Port thread Rc. NPT. are also available.

■ Magnetic as standard.

Table for standard stroke

	Tube I.D.	Stroke (mm)
Single acting	φ 16	15, 25, 50, 75, 100
	φ 20, 25	15, 25, 50, 75, 100, 125, 150
Double acting	φ 8, 10	10, 25, 40, 50, 80, 100
	φ 12	10, 25, 40, 50, 80, 100, 125, 160, 200
	φ 16	15, 25, 50, 75, 100, 125, 150, 200, 250, 300, 350, 400, 450, 500
	φ 20, 25	15, 25, 50, 75, 100, 125, 150, 200, 250, 300, 350, 400, 450, 500

※ Stroke out of specification is also available.
 ※ Please consult us if stroke out of specification.

Order example

MCFI - 11 - 16 - 100 - A - N

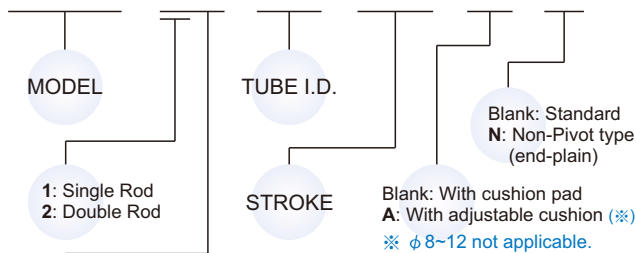

STYLE

Code	Symbol	Description
1 1		Double acting / Male thread
1 3		Single acting / Normally extended male thread
1 5		Single acting / Normally returned male thread
2 1		Double rod / Male thread
2 7		Double rod / Adjustable male thread Please mark "adjustable distance(mm)" at order list

※ Single acting type Please consult us.
 ※ Order example for special specification, refer to page J-03.

Specification

Model	MCFI					
Tube I.D. (mm)	8	10	12	16	20	25
Port size	M5 × 0.8			G1/8		
Medium	Air					
Max. operating pressure	0.7 MPa					
Min. operating pressure MPa	0.1	0.08		0.06		
Proof pressure	1 MPa					
Ambient temperature	- 5~ + 60°C (No freezing)					
Available speed range	50~500 mm/sec					
Lubricator	Not required					
Sensor switch (band) (※)	RCA (Matching the BA20,BA25 band) (Matching the BGS20,BGS25 band)					
	RCM (Matching the BM16~BM25 band)					
	RCS (Matching the BJ8~BJ16 band)					

※ RCA, RCM, RCS specification, please refer to page V-07, V-11, V-12.
 ※ The code of sensor switch band is BM16. "16" represents the tube I.D.

Mounting accessories

FA - MCFI - 16

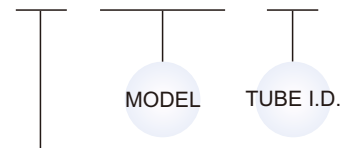

MOUNTING TYPE

	LB
	FA
	FB
	SDB
	Y
	I
	YS (Y+Floating pin)

φ 8, φ 12

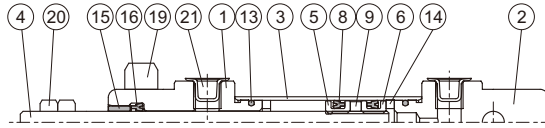

φ 10

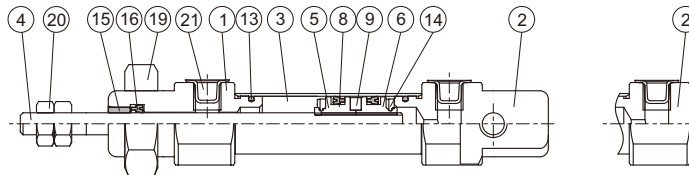

N type:
φ 8~ φ 25

φ 16, φ 20

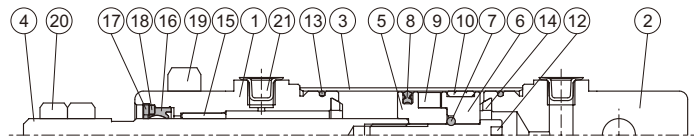

15 type: φ 16

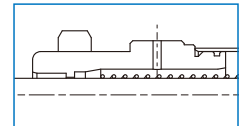

φ 25

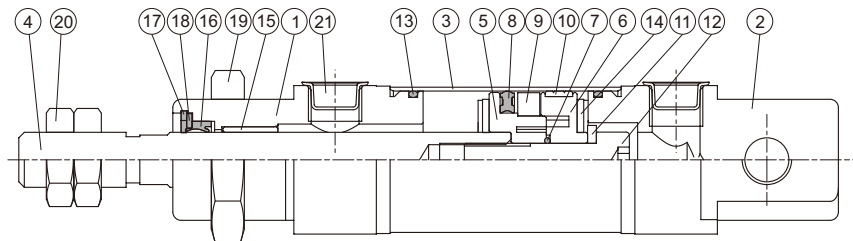

- ※ Style 21 is not applicable in cylinder bore φ 8~ φ 12.
- ※ Repair kit is not applicable for cylinder bore φ 8~ φ 12.
- ◎ Cylinder bore φ 8~12 (Required quantity : 2 pcs).

Material :

No.	Part name	Tube I.D.					Q'y		Component parts (inclusion)		Repair kits (inclusion)
		8	10	12	16	20	25	11 type	21 type	11 type	
1	Rod cover	Aluminum alloy					1	2	●	●	
2	Head cover	Aluminum alloy					1	—	●		
3	Tube	Stainless steel					1	1			
4	Piston rod	Stainless steel				※2	1	1			
5	Piston-R	Aluminum alloy				※1	1	1	●	●	
6	Piston-H	Aluminum alloy				※1	1	1	●	●	
7	Piston gasket	—				NBR	1	1	●	●	
8	Piston packing	NBR					1 ^(◎)	1 ^(◎)	●	●	
9	Magnet ring	Magnet material					1	1	●	●	
10	Wear ring	—				Teflon + Graphite	1	1	●	●	
11	Washer	—				※2	1	—	●		
12	Piston bolt	SCM					1	—	●		
13	Cover ring	NBR					2	2	●	●	
14	Cushion gasket	NBR					2	2	●	●	
15	Rod bush	Bearing alloy					1	2	●	●	
16	Rod packing	NBR					1	2	●	●	●
17	Snap ring	—				Spring steel	1	2	●	●	
18	Washer	—				Carbon steel	1	2	●	●	
19	Tie nut	Carbon steel					1	2	●	●	
20	Rod front nut	Carbon steel					2	2	●	●	
21	Port plug	Plastic					2	2	●	●	

Order example of component parts / repair kits

Tube I.D.	Component parts	Repair kits
φ 8	CP-MCFI-8	PS-MCFI-8
φ 10	CP-MCFI-10	PS-MCFI-10
φ 12	CP-MCFI-12	PS-MCFI-12
φ 16	CP-MCFI-16	PS-MCFI-16
φ 20	CP-MCFI-20	PS-MCFI-20
φ 25	CP-MCFI-25	PS-MCFI-25

Non-pivot type (end-plain)

Tube I.D.	Component parts
φ 8	CP-MCFI-8-N
φ 10	CP-MCFI-10-N
φ 12	CP-MCFI-12-N
φ 16	CP-MCFI-16-N
φ 20	CP-MCFI-20-N
φ 25	CP-MCFI-25-N

※1. Polyurethane ※2. Carbon steel

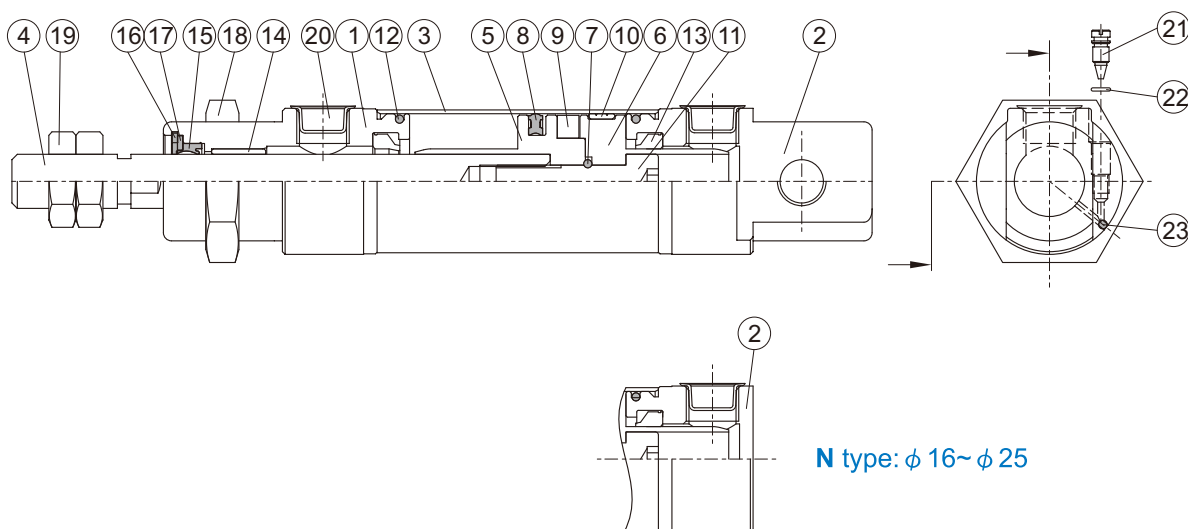

N type: $\phi 16 \sim \phi 25$

Material ※ Cylinder bore 8-12 is not applicable.

No.	Part name	Tube I.D.			Q'ty		Component parts (inclusion)		Repair kits (inclusion)
		16	20	25	11 type	21 type	11 type	21 type	
1	Rod cover	Aluminum alloy			1	2	●	●	
2	Head cover	Aluminum alloy			1	—	●		
3	Tube	Stainless steel			1	1			
4	Piston rod	※1	Carbon steel		1	1			
5	Piston-R	Aluminum alloy			1	1	●	●	
6	Piston-H	Aluminum alloy			1	1	●	●	
7	Piston gasket	NBR			1	1	●	●	
8	Piston packing	NBR			1	1	●	●	
9	Magnet ring	Magnet material			1	1	●	●	
10	Wear ring	Teflon + Graphite			1	1	●	●	
11	Piston bolt	SCM			1	—	●		
12	Cover ring	NBR			2	2	●	●	
13	Cushion packing	NBR			2	2	●	●	
14	Rod bush	Bearing alloy			1	2	●	●	
15	Rod packing	NBR			1	2	●	●	●
16	Snap ring	Spring steel			1	2	●	●	
17	Washer	Carbon steel			1	2	●	●	
18	Tie nut	Carbon steel			1	2	●	●	
19	Rod front nut	Carbon steel			2	2	●	●	
20	Port plug	Plastic			2	2	●	●	
21	Needle valve	Stainless steel			2	2	●	●	
22	Needle valve packing	NBR			2	2	●	●	●
23	Steel ball	Stainless steel			2	2	●	●	

※1. Stainless steel

Order example of component parts / repair kits

Tube I.D.	Component parts	Repair kits
$\phi 16$	CP-MCFI-16A	PS-MCFI-16A
$\phi 20$	CP-MCFI-20A	PS-MCFI-20A
$\phi 25$	CP-MCFI-25A	PS-MCFI-25A

Non-pivot type (end-plain)

Tube I.D.	Component parts
$\phi 16$	CP-MCFI-16A-N
$\phi 20$	CP-MCFI-20A-N
$\phi 25$	CP-MCFI-25A-N

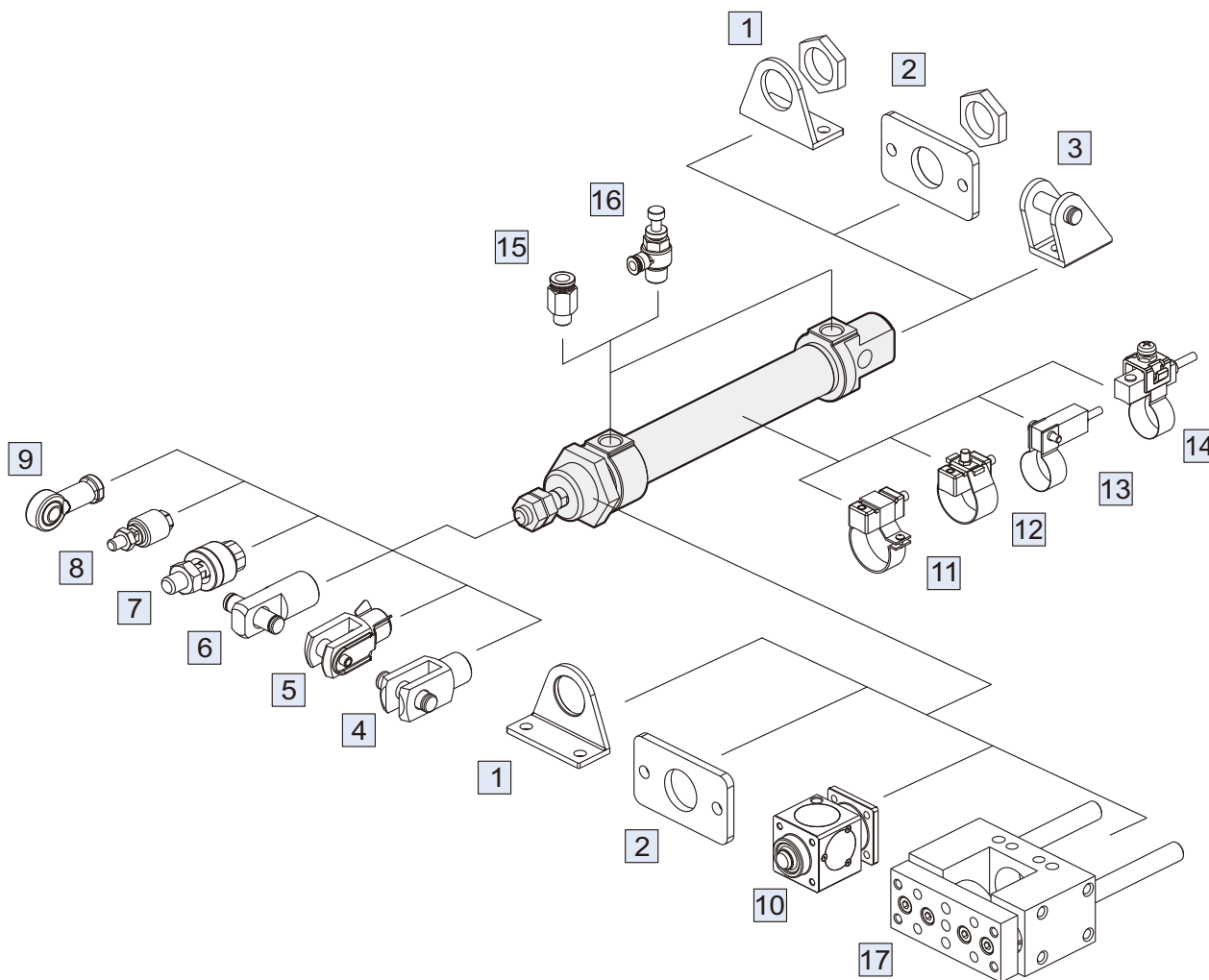

No.	Accessories	Page
1	Mounting accessories LB	L-43
2	Mounting accessories FA/FB	L-42
3	Mounting accessories SDB+PIN	L-32,13
4	Accessories Y+PIN	L-13
5	Accessories Y+Floating pin	L-13
6	Accessories I+PIN	L-13
7	Floating joint MFC	V-01
8	Floating joint MFCS	V-03
9	Female rod ends PHS	V-04

No.	Accessories	Page
10	Locking unit MCBMI	J-75
11	Sensor switch RCA+BGS**	V-05
12	Sensor switch RCA+BA**	V-05
13	Sensor switch RCM+BM**	V-11
14	Sensor switch RCS+BJ**	V-12
15	Fitting PC	H-03
16	Fitting JSC	H-14
17	Twin-guide cylinders MGTB/ TK/ TU	K-24

11

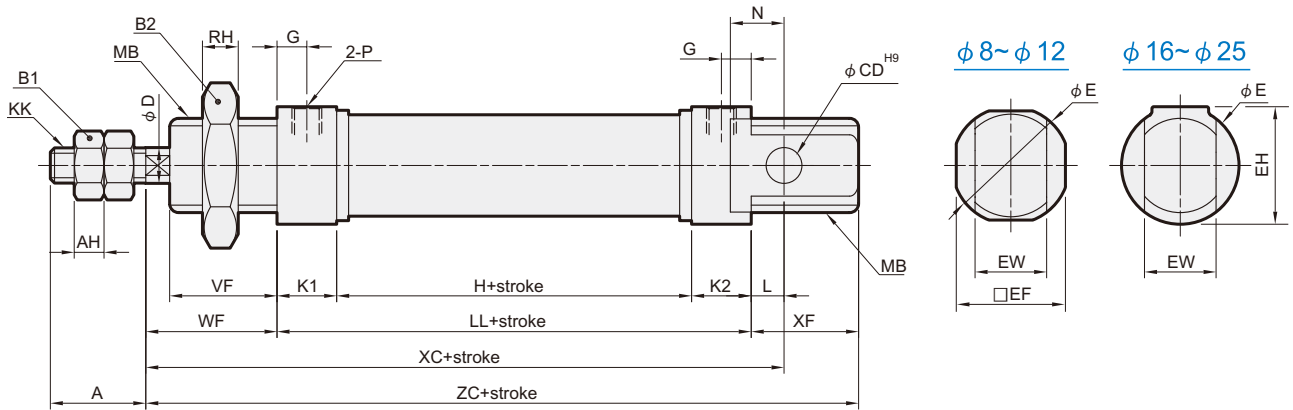

21

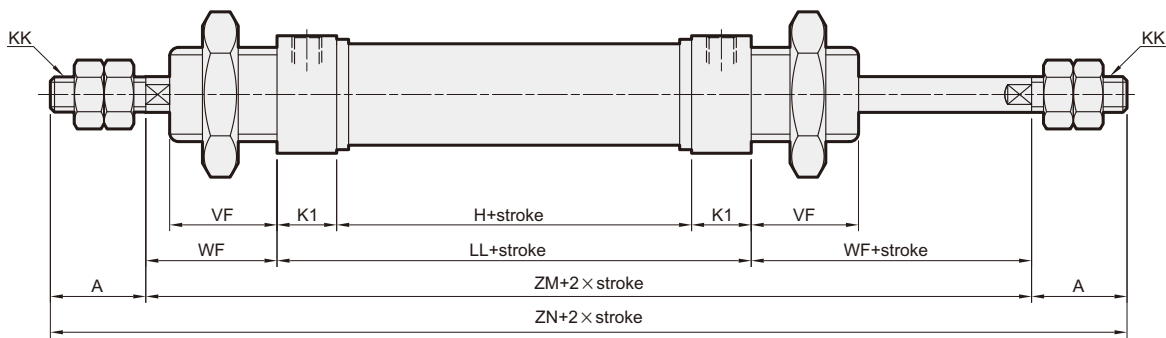

27

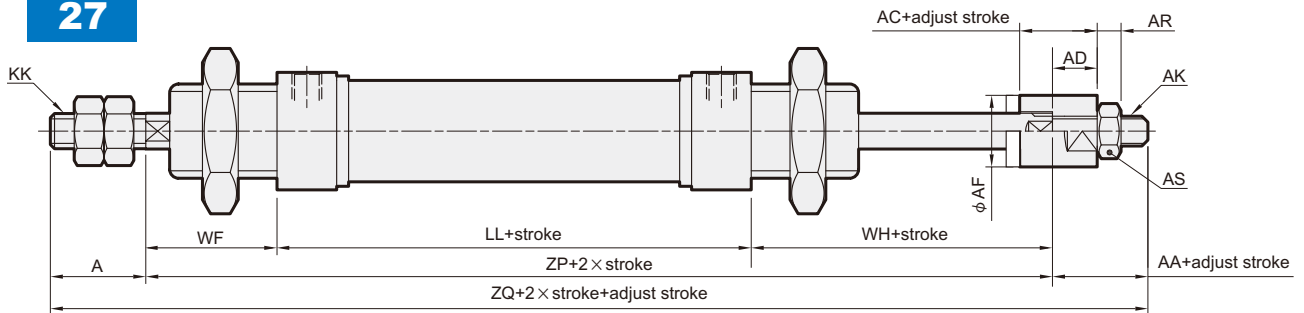

Code Tube I.D.	A	AA	AC	AD	AF	AH	AK	AR	AS	B1	B2	CD	D	E	EF	EH	EW	G	H	KK	K1	K2	L	LL
8	12	—	—	—	—	3.2	—	—	—	7	19	4	4	16.7	15	—	8 ^{-0.05} _{-0.4}	6	24	M4×0.7	11	11	2	46
10	12	—	—	—	—	3.2	—	—	—	7	19	4	4	16.7	15	—	8 ^{-0.05} _{-0.4}	6	24	M4×0.7	11	11	2	46
12	16	—	—	—	—	5	—	—	—	10	24	6	6	19.7	18.3	—	12 ^{-0.05} _{-0.4}	6	28	M6×1.0	11	11	3	50
16	16	16	13	7.5	12	5	M5×0.8	4	8	10	22	6	6	20	—	20	12 ^{-0.05} _{-0.4}	5	34.5	M6×1.0	10	10	5.5	54.5
20	20	19	15	9.5	16	5	M8×1.25	5	13	13	30	8	8	27	—	27	16 ^{-0.05} _{-0.4}	8	38	M8×1.25	15	15	3	68
25	22	19	15	9.5	16	5	M8×1.25	5	13	17	30	8	10	27	—	27	16 ^{-0.05} _{-0.4}	7.5	37	M10×1.25	15	15	9	67

Code Tube I.D.	MB	N	P	RH	VF	WF	WH	XC	XF	ZC	ZM	ZN	ZP	ZQ
8	M12×1.25	6	M5×0.8	6	12	16	—	64	12	74	—	—	—	—
10	M12×1.25	6	M5×0.8	6	12	16	—	64	12	74	—	—	—	—
12	M16×1.5	9	M5×0.8	8	17	22	—	75	17	89	—	—	—	—
16	M16×1.5	9	M5×0.8	6	18	22	25.5	82	18	94.5	98.5	130.5	102	134
20	M22×1.5	12	G1/8	6	20	24	27	95	20	112	116	156	119	158
25	M22×1.5	12	G1/8	6	22	28	29.5	104	22	117	123	167	124.5	165.5

Sensor switch: RCA
Sensor switch band: BA**

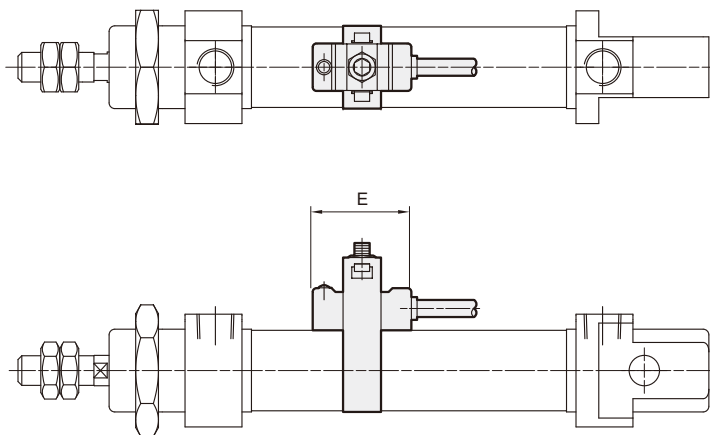
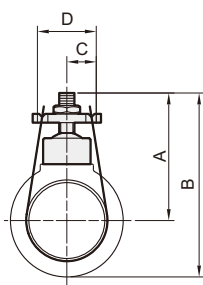

Code Tube I.D.	A	B	C	D	E
20	33	48	9	18	26
25	35.5	50.5	9	18	26

Sensor switch: RCA
Sensor switch band: BGS**

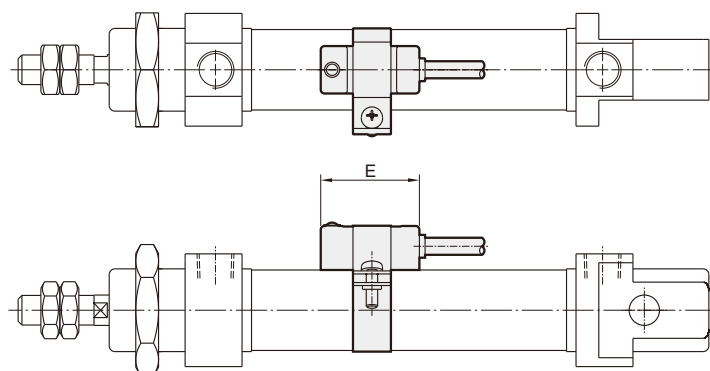
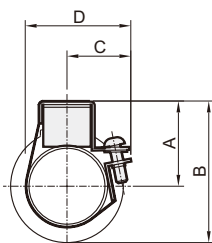

Code Tube I.D.	A	B	C	D	E
20	25	40	18	33	26
25	25.5	40.5	18.5	33.5	26

Sensor switch: RCM
Sensor switch band: BM**

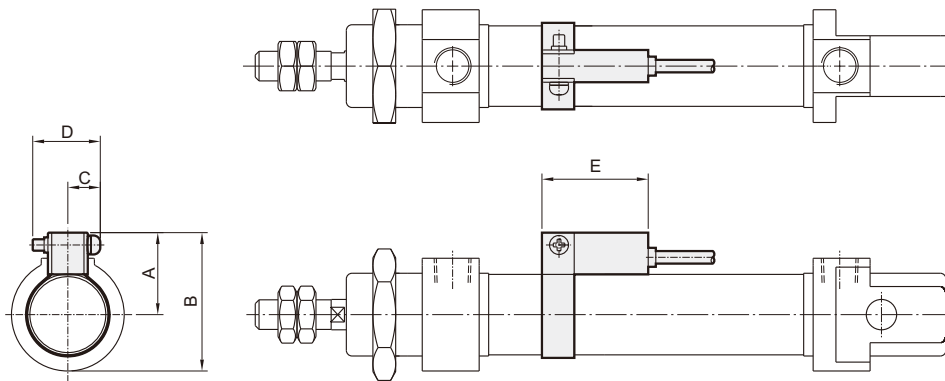

Code Tube I.D.	A	B	C	D	E
16	20	30	10	16	28
20	22	37	10	16	28
25	25	40	10	16	28

Sensor switch: RCS
Sensor switch band: BJ**

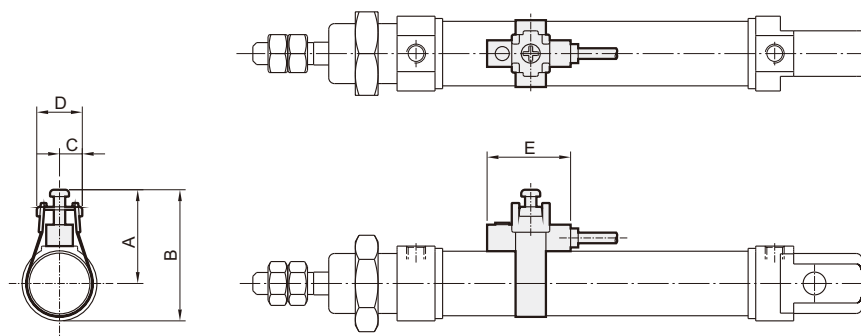

Code Tube I.D.	A	B	C	D	E
8	19.1	26.6	6	12	22
10	20.1	27.6	6	12	22
12	21.3	30.5	6	12	22
16	23.4	33.3	6	12	22

13 15

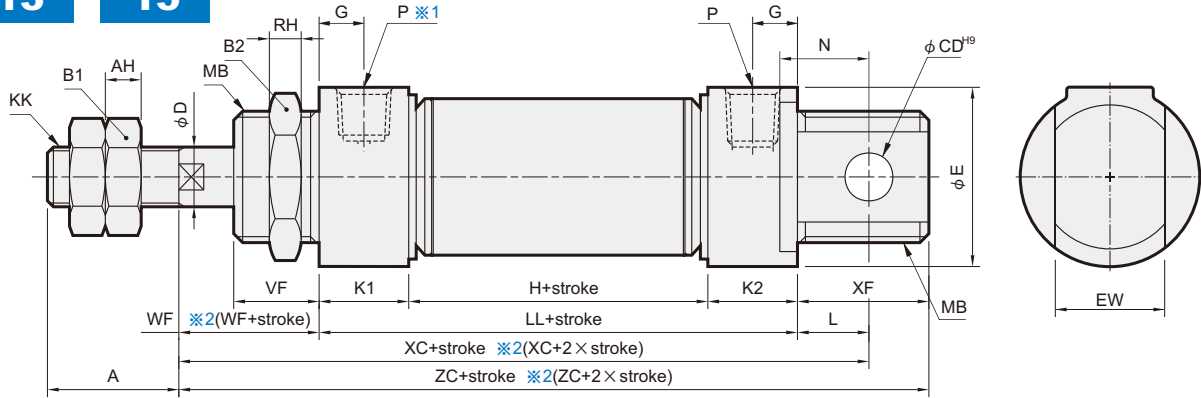

※1. 15 type $\phi 16$ without this air port
 ※2. () Dimension for 13 type

Code Tube I.D.	A	AH	B1	B2	CD	D	E	EW	G	KK	K1	K2	L	LA	MB	N	P	RH	VF	WF	XF	ZM	ZN	ZP	ZQ
16	16	5	10	22	6	6	20	$12_{-0.05}^{0.05}$	5	M6×1.0	10	10	5.5	54.5	M16×1.5	9	M5×0.8	6	18	22	18	98.5	130.5	96	134
20	20	5	13	30	8	8	27	$16_{-0.05}^{0.05}$	8	M8×1.25	15	15	3	68	M22×1.5	12	G 1/8	6	20	24	20	116	156	119	158
25	22	6	17	30	8	10	27	$16_{-0.05}^{0.05}$	7.5	M10×1.25	15	15	9	67	M22×1.5	12	G 1/8	6	22	28	22	123	167	124.5	165.5

MCFM-13

Code Stroke I.D.	H			LL			XC			ZC		
	1~50	51~100	101~150	1~50	51~100	101~150	1~50	51~100	101~150	1~50	51~100	101~150
16	53.5	79.5	105.5	73.5	99.5	125.5	101	127	153	113.5	139.5	165.5
20	63	88	113	93	118	143	120	145	170	137	162	187
25	60.5	85.5	110.5	90.5	115.5	140.5	127.5	152.5	177.5	140.5	165.5	190.5

MCFM-15

Code Stroke I.D.	H			LL			XC			ZC		
	1~50	51~100	101~150	1~50	51~100	101~150	1~50	51~100	101~150	1~50	51~100	101~150
16	34.5	50	65.5	54.5	70	85.5	82	97.5	113	94.5	110	125.5
20	38	88	113	68	118	143	95	145	170	112	162	187
25	37	85.5	110.5	67	115.5	140.5	104	152.5	177.5	117	165.5	190.5

Mounting accessories / Double acting

FA / FB

Code Tube I.D.	A	FB	FE	FF	FP	FT	KK	W	ZC	ZF
8	12	4.5	22	40	30	3.2	M4×0.7	12.8	74	65.2
10	12	4.5	22	40	30	3.2	M4×0.7	12.8	74	65.2
12	16	5.5	26	52	40	3.2	M6×1.0	18.8	89	75.2
16	16	5.5	26	52	40	3.2	M6×1.0	18.8	94.5	79.7
20	20	6.6	38	64	50	4.5	M8×1.25	19.5	112	96.5
25	22	6.6	38	64	50	4.5	M10×1.25	23.5	117	99.5

MCFM- $\phi 12, \phi 16$

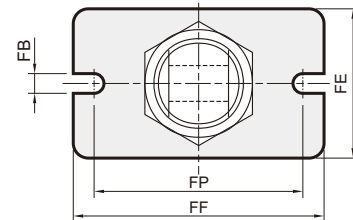

MCFM- $\phi 8, \phi 10, \phi 20, \phi 25$

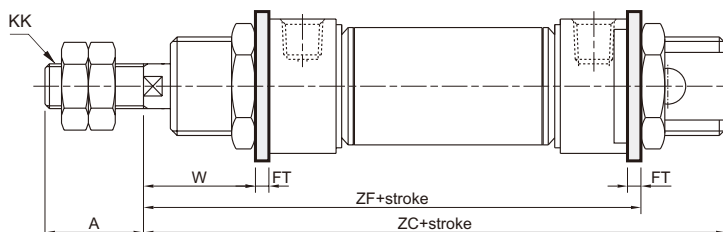
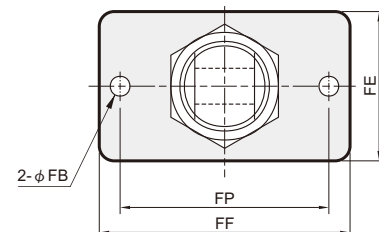

SDB

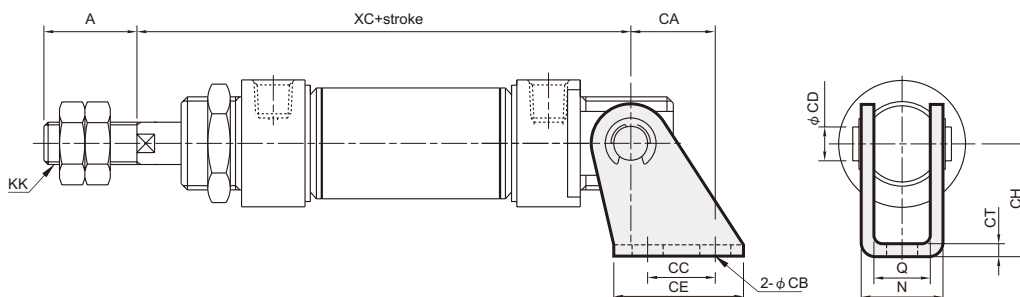

Code Tube I.D.	A	CA	CB	CC	CD	CE	CH	CT	KK	N	Q	XC
8	12	11	4.5	12.5	4	20	24	2.5	M4×0.7	13.1	8.1	64
10	12	11	4.5	12.5	4	20	24	2.5	M4×0.7	13.1	8.1	64
12	16	13	5.5	15	6	25	27	3.2	M6×1.0	18.5	12.1	75
16	16	13	5.5	15	6	25	27	3.2	M6×1.0	18.5	12.1	82
20	20	16	6.6	20	8	32	30	3.2	M8×1.25	22.5	16.1	95
25	22	16	6.6	20	8	32	30	3.2	M10×1.25	22.5	16.1	104

LB

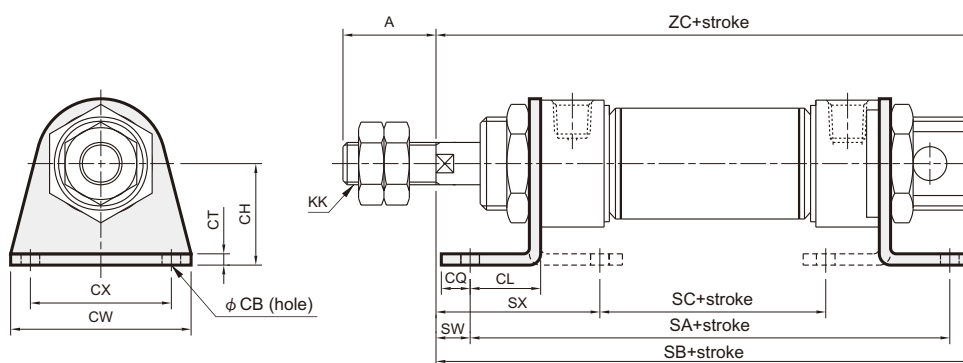

Code Tube I.D.	A	CB	CH	CL	CQ	CT	CW	CX	KK	SA	SB	SC	SW	SX	ZC
8	12	4.5	16	11	5	3.2	35	25	M4×0.7	68	78	30.4	5	23.8	74
10	12	4.5	16	11	5	3.2	35	25	M4×0.7	68	78	30.4	5	23.8	74
12	16	5.5	20	14	6	4	42	32	M6×1.0	78	92	30	8	32	89
16	16	5.5	20	14	6	4	42	32	M6×1.0	82.5	96.5	34.5	8	32	94.5
20	20	6.6	25	15	8	3.2	54	40	M8×1.25	98	115	44.4	9	35.8	112
25	22	6.6	25	15	8	3.2	54	40	M10×1.25	97	118	43.4	13	39.8	117

N

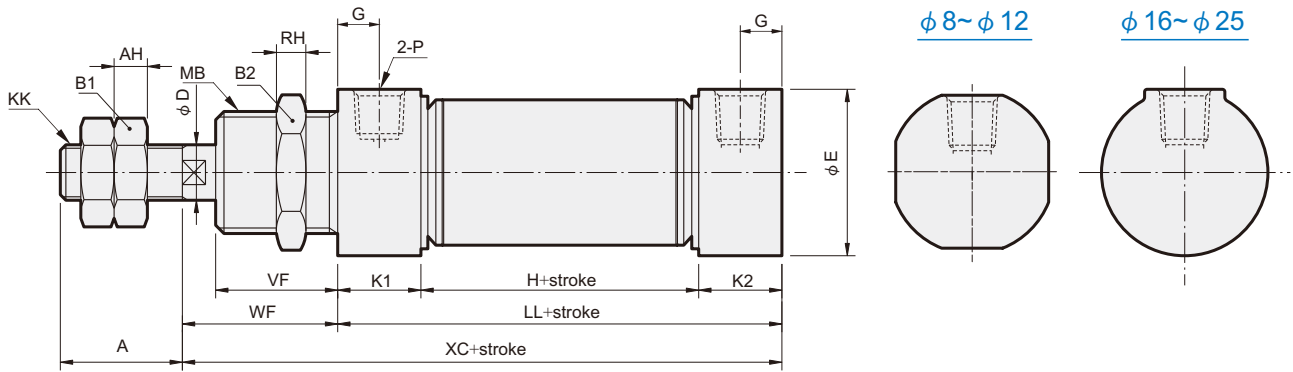

Code Tube I.D.	A	AH	B1	B2	D	E	G	H	KK	K1	K2	LL	MB	P	RH	VF	WF	XC
8	12	3.2	7	19	4	16.7	6	24	M4×0.7	11	11	46	M12×1.25	M5×0.8	6	12	16	62
10	12	3.2	7	19	4	16.7	6	24	M4×0.7	11	11	46	M12×1.25	M5×0.8	6	12	16	62
12	16	5	10	24	6	19.7	6	28	M6×1.0	11	11	50	M16×1.5	M5×0.8	8	17	22	72
16	16	5	10	22	6	20	5	34.5	M6×1.0	10	10	54.5	M16×1.5	M5×0.8	6	18	22	76.5
20	20	5	13	30	8	27	8	38	M8×1.25	15	15	68	M22×1.5	G1/8	6	20	24	92
25	22	6	17	30	10	27	7.5	37	M10×1.25	15	15	67	M22×1.5	G1/8	6	22	28	95

FA

Code Tube I.D.	A	FB	FE	FF	FP	FT	W	XC
8	12	4.5	22	40	30	3.2	12.8	62
10	12	4.5	22	40	30	3.2	12.8	62
12	16	5.5	26	52	40	3.2	18.8	72
16	16	5.5	26	52	40	3.2	18.8	76.5
20	20	6.6	38	64	50	4.5	19.5	92
25	22	6.6	38	64	50	4.5	23.5	96

MCFM- $\phi 12, \phi 16$

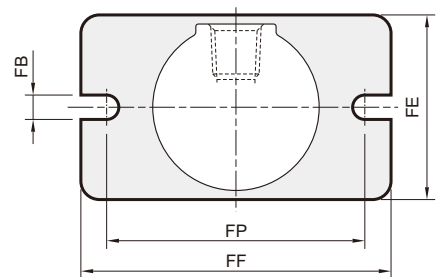

MCFM- $\phi 8, \phi 10, \phi 20, \phi 25$

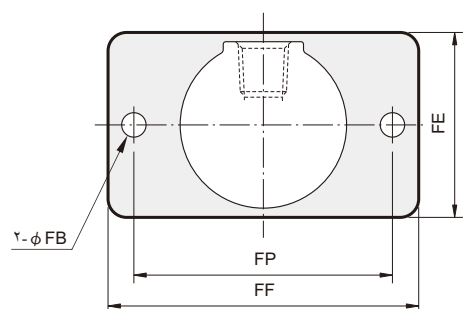
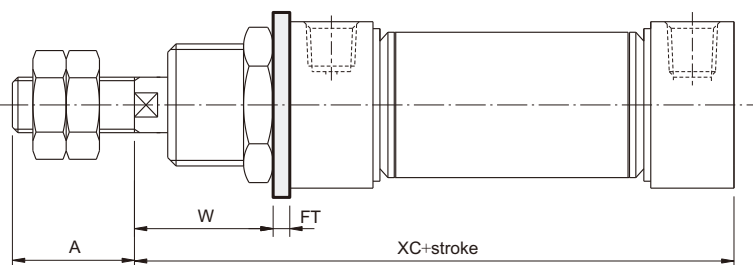

Y connector

$\phi 8 \sim \phi 16$

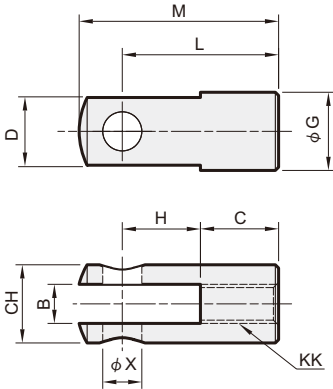

$\phi 20 \sim \phi 40$

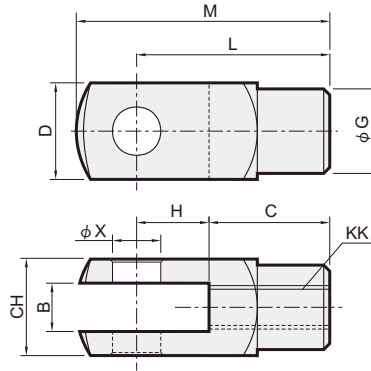

I connector

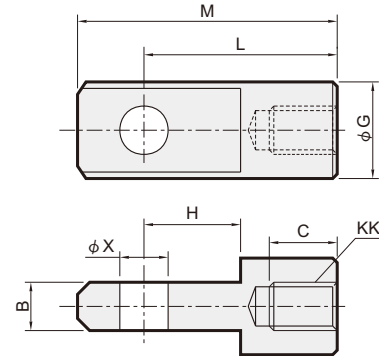

Code Tube I.D.	B		C		CH		D		G		H		KK		L		M		X ^{H9}
	Y	I	Y	I	Y	I	Y	I	Y	I	Y	I	Y	I	Y	I	Y	I	
8,10	4 ^{+0.4} _{+0.1}		8		8		8				8		M4×0.7		16		20.75		4 ^{+0.03} ₊₀
12,16	6 ^{+0.4} _{+0.1}	6 ^{-0.2} _{-0.3}	12	8	12				12	12	12	10	M6×1		24	21	31	28	6 ^{+0.03} ₊₀
20	8 ^{+0.5} _{+0.15}	8 ^{-0.1} _{-0.2}	16	14	16		16		14	16	16	12	M8×1.25		32	32	42	42	8 ^{+0.036} ₊₀
25,32	10 ^{+0.5} _{+0.15}	10 ^{-0.1} _{-0.2}	20	17	19		19		18	20	20	15	M10×1.25		40	40	52	52	10 ^{+0.036} ₊₀
40	12 ^{+0.5} _{+0.15}	12 ^{-0.1} _{-0.2}	24	21	22		22		20	24	24	18	M12×1.25		48	48	62	62	12 ^{+0.043} ₊₀

Pin

Order example ※ Only for Y connector and $\phi 20 \sim 40$ tube I.D.
※ $\phi 16$ tube I.D. use this order : **YS-MCMA-16**.

PIN - MCMA - 16 - Y - P

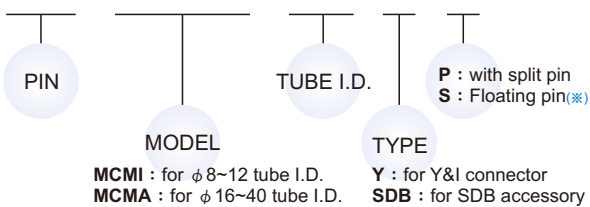

$\phi 8 \sim \phi 16$

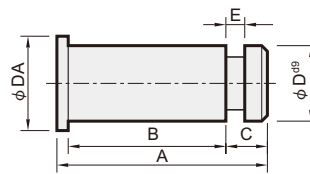

$\phi 20 \sim \phi 40$

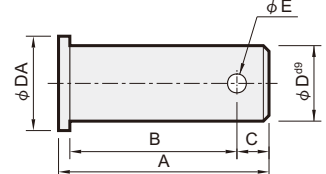

for Y & I connector

Code Tube I.D.	A	B	C	D ^{H9}	DA	E	Split pin
8,10	12	8.5	2	4 ^{-0.03} _{-0.06}	8	0.7	E3
12,16	18.5	15	2	6 ^{-0.03} _{-0.06}	10	0.7	E4
20	24.5	20.5	2.5	8 ^{-0.04} _{-0.08}	12	$\phi 2.5$	2.5×16L
25,32	30	25	3.5	10 ^{-0.04} _{-0.08}	14	$\phi 3.2$	3.2×20L
40	37	30	5	12 ^{-0.05} _{-0.09}	16	$\phi 3.2$	3.2×20L

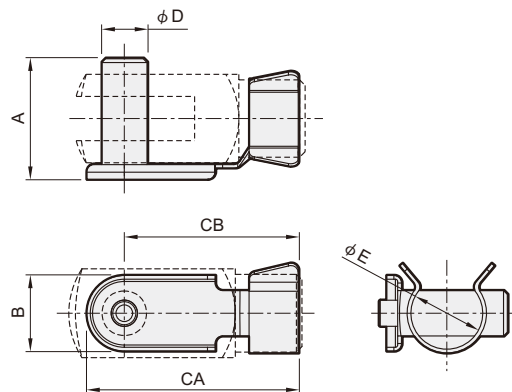

for floating pin

Code Tube I.D.	A	B	CA	CB	D ^{H9}	E
32	26	14	45	38	$\phi 10$ ^{-0.06} _{-0.09}	17
40	31	16	54	46	$\phi 12$ ^{-0.06} _{-0.09}	19
50,63	42	20	70	60	$\phi 16$ ^{-0.05} _{-0.09}	27
80,100	56	30	91	76	$\phi 20$ ^{-0.06} _{-0.11}	35

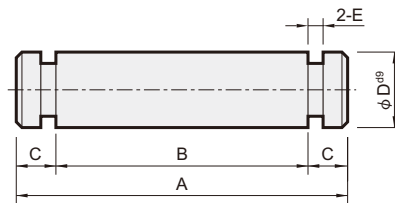

for SDB

Code Tube I.D.	A	B	C	D ^{H9}	E	Split pin
8,10	18	14	2	4 ^{-0.03} _{-0.06}	0.7	E3.2
12	23.5	19.5	2	6 ^{-0.03} _{-0.06}	0.7	E5
16	21	17	2	6 ^{-0.03} _{-0.06}	0.7	E5
20,25	30	25	2.5	8 ^{-0.04} _{-0.08}	0.9	E7
32	33	27	3	10 ^{-0.04} _{-0.08}	0.9	E9
40	37	31	3	12 ^{-0.05} _{-0.09}	0.9	E9